

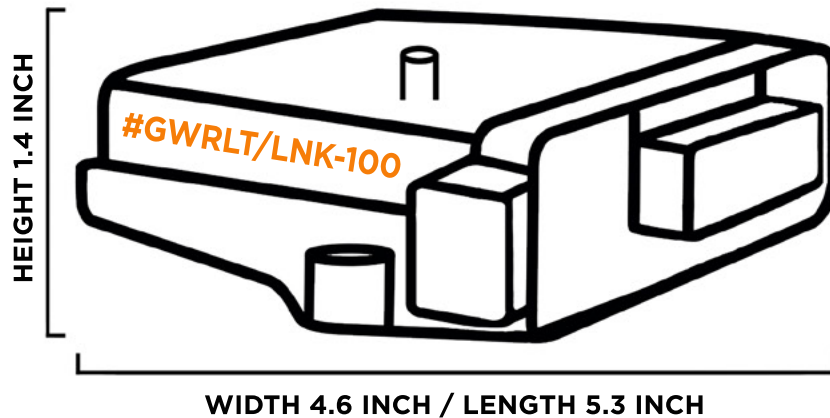

PressurePro's Gateway Lite/LINK LT Solution, which first debuted with Version 2 Intelligent Product, remains a critical product in PressurePro's lineup. A critical component across all of PressurePro's aftermarket and OE applications, Gateway Lites are utilized extensively across light, medium and heavy duty installations. Similar to its 'parent product', the Gateway, the Gateway Lite is capable of reading up to 32 tires and features CAN and RS232 capabilities, allowing tire performance information to be transferred across a vehicle network giving users the same seamless integration to Telematics or Infotainment solutions, at a reduced price. Advanced features also include complete alert and reference pressure customization.

PressurePro, the Global Standard in TPMS.



GATEWAY LITE WEIGHT | 240.9 grams / 8.5 ounces

CONFORMITY | FCC, IC, CE, RoHS

ENVIRONMENTAL TESTING | Select J1455, MIL-STD-202G and MIL-STD-810G

TEMPERATURE RANGE | -40° to 85°C

POWER | 12-36 volts, surge protection to 60V (typical draw = 150 mA at 12V)

ENCLOSURE | Weather-resistant (IP67) Deutsch enclosure with 12-pin connector
Intended for interior or exterior installation

COMMUNICATION | CAN/J1939 and RS232 protocols

RECEPTION RANGE* | 100' average with max of 1000'

PREFERRED ANTENNA | LINK Coax Kit

TIRE CAPABILITY | Up to 32 tires (16 per SA/2 SA capability)

CUSTOMIZATION | Allows users to customize alert levels/reference pressures

MANUFACTURING | **Designed and Manufactured in the USA**

*Gateway Lite reception range is dependent on the vehicle environment and receiver antenna location.